



**Third Sunday of Easter
Holy Communion
April 19, 2026**

*Directionally
challenged?*

Cover photo by
Donovan Drake.

*Worship on the
Lord's Day*

Worship begins as the people gather - greeting one another, praying in silence, or offering music to the glory of God. The act of assembling in Jesus' name bears witness to the Church's identity and mission as Christ's body in the world.

About the Prelude

The Prelude is a musical offering to help move the hearts and minds of the gathering community from the daily struggles of life to the worship of God.

About Hymn 257

This perceptive hymn centers on Christ's post-Resurrection appearances described in John 20:19-29 and Luke 24:13-48. The first three stanzas are shaped by the wounded body parts: feet, side, hand; the fourth prays for such woundedness in the witness of Christ's body, the Church.

GATHERING

CONCERNS OF THE CHURCH

*CALL TO WORSHIP

Let us worship God!

(Those who are able may stand.)

Jesus the Christ has freed us from death
and brought us into new life.

Through Christ, we have faith and hope in God.

In genuine, mutual love,
let us worship with one heart and one voice.

In reverence and joy, we praise God's holy name!

PRELUDE

Joe Utterback

I Want Jesus to Walk with Me

*PRAYER OF THE DAY

The Lord be with you. **And also with you.**

**Risen and Living God,
in your endless love and grace,
you have given us all we need.
Open our weary eyes
to moments when need meets resource
and longing is satisfied in giving.
Send us where you need us
and fill us with your purpose,
so that all people may know the wonder and joy
of your redeeming presence,
through Jesus the Christ. Amen.**

*(The Cross and Bible lead the procession, symbolic of the centrality
in worship of Jesus Christ - the Living Word,
and the Bible - the written Word.)*

*PROCESSIONAL HYMN 257

WOODLANDS

The Risen Christ

The Risen Christ

257

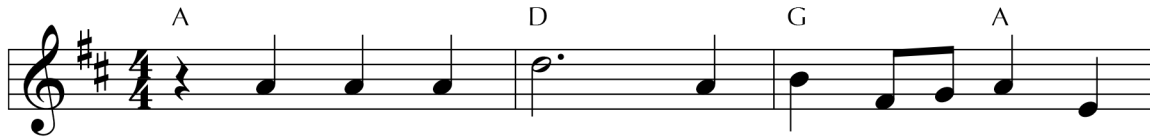

1 The ris - en Christ, who walks on wound - ed
 2 The ris - en Christ, who stands with wound - ed
 3 The ris - en Christ, who breaks with wound - ed
 4 May we, Christ's bod - y, walk and serve and



feet from gar - den tomb through dark - ened cit - y
 side, breathes out his Spir - it on them to a -
 hand the bread for those who fail to un - der -
 stand with the op - pressed in this and ev - ery



street, un - locks the door of grief, de - spair, and fear, and
 bide whose faith still wa - vers, who dare not be - lieve; new
 stand, re - veals him - self, de - spite their lin - gering tears, en -
 land, till all are blessed and can a bless - ing be, re -

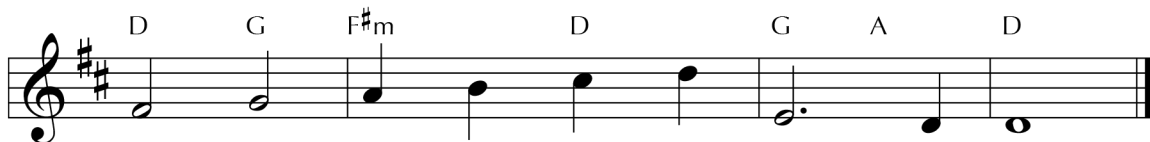

speaks a word of peace to all who hear.
 grace, new strength, new pur - pose they re - ceive.
 flames their hearts, then quick - ly dis - ap - pears.
 stored in Christ to true hu - man - i - ty.

Guitar chords do not correspond with keyboard harmony.

This perceptive hymn centers on Christ's post-Resurrection appearances described in John 20:19–29 and Luke 24:13–48. The first three stanzas are shaped by the wounded body parts: feet, side, hand; the fourth prays for such woundedness in the witness of Christ's body, the Church.

CALL TO CONFESSION

If we say we have no sin,
we deceive ourselves, and the truth is not in us.

If we confess our sins,
God who is faithful and just will forgive us our sins
and cleanse us from all unrighteousness. (1 John 1:8-9)
In humility and faith, let us confess our sin to God.

PRAYER OF CONFESSION

The Lord be with you. And also with you.

Merciful God,
you pardon all who truly repent and turn to you.
We humbly confess our sins and ask your mercy.
We have not loved you with a pure heart,
nor have we loved our neighbor as ourselves.
We have not done justice, loved kindness,
or walked humbly with you, our God.
Have mercy on us, O God, in your loving kindness.
In your great compassion,
cleans us from our sin.
Create in us a clean heart, O God,
and renew a right spirit within us.
Do not cast us from your presence,
or take your Holy Spirit from us.
Restore to us the joy of your salvation
and sustain us with your bountiful Spirit. Amen.

(Silent confession)

Kyrie

James MacMillan

(Organ introduction) $\frac{4}{4}$ 1st-Choir/2nd-Congregation

Lord, have mer-cy, Lord, have
mer-cy. Christ, have mer-cy, Christ, have
mer-cy. Lord, have mer-cy, Lord, have mer-cy.

Call to and Prayer of Confession

A call to confession expresses God's initiative in calling for repentance and promising forgiveness in Christ. As members of Christ's body, we confess the reality of sin, captivity, and brokenness in personal and common life and ask for God's saving grace.

About the Kyrie
The Kyrie (Greek "kyrios" [Lord]) is a corporate musical prayer for grace.

ASSURANCE OF PARDON

Believe the Good News:
In Jesus Christ we are forgiven!

***The Peace**

Since God in Christ has forgiven us,
let us also forgive one another.

The peace of Christ be with you.
And also with you.

*(Please exchange the peace with the words,
"The peace of Christ be with you.")*

Act of Praise

The Act of Praise brings together the choir and congregation to sing God's praise in response to the Assurance of Pardon as the last phrase.

ACT OF PRAISE (Hymn 513)

FESTIVAL CANTICLE

This Is the Feast of Victory

(The congregation is invited to sing with the choir.)

**Refrain: This is the feast of victory for our God.
Alleluia, alleluia, alleluia!**

**Sing with all the people of God,
and join in the hymn of all creation. *Refrain.***

Scripture

The scriptures bear witness to the word of God, revealed most fully in Jesus Christ, the Word who "became flesh and lived among us." (John 1:14) Where the word is read and proclaimed, Jesus Christ the living Word is present by the power of the Holy Spirit. Therefore, reading, hearing, preaching, and affirming the word are central to Christian worship and essential to the Service for the Lord's Day.

THE WORD

PRAYER FOR ILLUMINATION

SCRIPTURE

Hear the Word of God! **Our ears are open.**

1 Peter 1:17-23

(New Testament, page 232 in your pew Bible)

The Word of the Lord. **Thanks be to God!**

Psalm 116

Philip Stopford

In the Land of the Living

I love the Lord,
for he has heard the voice of my supplication,
because he inclined his ear to me
on the day I called to him.

The snares of death encompassed me;
the pains of hell took hold of me;
by grief and sorrow was I held.

I will walk before the Lord
in the land of the living.

Then I called upon the name of the Lord:
“O Lord, I beg you, deliver my soul!”
Gracious is the Lord, and righteous;
our God is full of compassion.
The Lord watches over the simple;
I was brought very low and he saved me.
Turn again to your rest, O my soul,
for the Lord has been gracious to you.

I will walk before the Lord
in the land of the living.

For you have delivered my soul from death,
delivered my soul, delivered my soul from death,
my eyes from tears, and my feet from falling;
my eyes from tears, and my feet, my feet from falling,
in the land of the living.

Luke 24:13-35

(New Testament, page 90 in your pew Bible)

The Word of the Lord. **Thanks be to God!**

SERMON "Directionally Challenged" Donovan Drake

(A moment for meditation)

***AFFIRMATION OF FAITH**

**Life in Christ is life eternal.
The resurrection of Jesus is the sign
that God will consummate the work
of creation and reconciliation beyond death
and bring to fulfillment
the new life begun in Christ.**

Adapted from the Confession of 1967, 9.26

THANKSGIVING

OFFERING

Anthem

Carl Schalk

Day of Arising

Offering

The collection of tithes and offerings takes place as a response to the Word. These actions are signs of our gratitude for the grace of God proclaimed in the gospel.

To give, please scan the QR code below:



Day of arising, Christ on the roadway,
unknown companion walks with his own.
When they invite him, as fades the first day,
and bread is broken, Christ is made known.

When we are walking, doubtful and dreading,
blinded by sadness, slowness of heart,
yet Christ walks with us ever awaiting
our invitation: Stay, do not part.

Lo, I am with you, Jesus has spoken.
This is Christ's promise, this is Christ's sign:
when the church gathers, when bread is broken,
there Christ is with us in bread and wine.

Christ, our companion, hope for the journey,
bread of compassion, open our eyes.
Grant us your vision, set all hearts burning
that all creation with you may rise.

Doxology

A short hymn of praise to the triune God (God, Jesus Christ, Holy Spirit).

*DOXOLOGY

LASST UNS ERFREUEN

**Praise God, from whom all blessings flow;
Praise God, all creatures here below: Alleluia! Alleluia!
Praise God, the source of all our gifts!
Praise Jesus Christ, whose power uplifts!
Praise the Spirit, Holy Spirit! Alleluia! Alleluia! Alleluia!**

*PREPARATION OF THE LORD'S TABLE

*INVITATION

*GREAT PRAYER OF THANKSGIVING

The Lord be with you. **And also with you.**
Lift up your hearts. **We lift them to the Lord.**

Let us give thanks to the Lord our God.
It is right to give our thanks and praise.

We lift our praise to you, Gardener of Creation...
...you became one of us that you might lead us back to you.

Therefore we join our glad songs of Easter
with those in every time and in every place,
who sing to you their praise:

ALL:

Ho - ly, ho - ly, ho - ly Lord. God of
pow - er and might. Heav - en and earth are full of your glo - ry. Ho - san -
na, ho - san - na, ho - san - na in the high - est! Bles - sed is
he who comes, he who comes in the name of the Lord. Ho -
san - na, ho - san - na, ho - san - na in the high - est!

(The congregation may be seated.)

You alone are holy, Steadfast God, and blessed is your Son...
...that we might enter the gates of righteousness.

As we remember you raising him
from the dead and giving us life,
We proclaim our faith:

Christ has died, Christ is ris - en, Christ will come a - gain.

Here at this Table we are nourished by your steadfast love...

...Then, when we are united with all the saints,
may we gather around your Table, one people,
and lift our voices in praise to you.

ALL:

[organ] A - men, A - men, A - men.

***THE LORD'S PRAYER**

**Our Father, who art in heaven,
hallowed be thy name,
thy kingdom come,
thy will be done,
on earth as it is in heaven.
Give us this day our daily bread;
and forgive us our debts,
as we forgive our debtors;
and lead us not into temptation,
but deliver us from evil.
For thine is the kingdom, and the power,
and the glory, forever. Amen.**

BREAKING OF THE BREAD

COMMUNION OF THE PEOPLE

Music during Communion

Air

Joe Utterback

Anthem

8:30 AM

Jacques Bertheir/Taize

Eat This Bread

Refrain:

Eat this bread, drink this cup,
come to me and never be hungry.

Eat this bread, drink this cup,
trust in me and you will not thirst.

I am the bread of life,
the true bread sent from the creator. *Refrain*

Your ancestors ate manna in the desert,
but this is the bread come down from heaven. *Refrain*

Anyone who eats this bread, will live forever. *Refrain*

If you believe and eat this bread,
you will have eternal life. *Refrain*

(11:00 AM)

Egil Hovland

Stay With Us

Stay with us, Lord Jesus, stay with us.
Stay with us, it soon is evening,
Stay with us, Lord Jesus, stay with us,
it soon is evening, and night is falling.

Jesus Christ, the world's true light!
Shine so the darkness cannot overcome it!
Stay with us, Lord Jesus, it soon is evening.
Stay with us, Lord Jesus, for night is falling.
Let your light pierce the darkness
and fill your church with its glory.

Stay with us, Lord Jesus, stay with us.
Stay with us, it soon is evening,
Stay with us, Lord Jesus, stay with us,
it soon is evening, and night is falling.

PRAYER AFTER COMMUNION

SENDING

*HYMN 500

Be Known to Us in Breaking Bread

ST. FLAVIAN

*BENEDICTION

POSTLUDE

Cornet Voluntary

Joe Utterback

About Hymn 500

Not all communion texts refer to the Last Supper: this brief hymn is based on the meal at Emmaus shared by the Risen Christ and his two companions on the road (Luke 24:13-35). It is set to a 16th-century psalm tune that carries the text with appropriate simplicity.

About the Postlude

The Postlude is considered the final Alleluia of worship.

*(Those who are able may stand.)

Be Known to Us in Breaking Bread 500

1 Be known to us in break-ing bread, but do not then de - part;
2 Here share with us, in love di - vine, your bod - y and your blood,

Sav - ior, a - bide with us, and spread your ta - ble in our heart.
that liv - ing bread, that heaven-ly wine be our im - mor - tal food.

Not all communion texts refer to the Last Supper: this brief hymn is based on the meal at Emmaus shared by the Risen Christ and his two companions on the road (Luke 24:13–35). It is set to a 16th-century psalm tune that carries the text with appropriate simplicity.

Today @ Westminster

Worship Leaders

Preaching

Rev. Dr. Donovan Drake
Pastor and Head of Staff

Liturgist

Rev. Sarah Bird Kneff
Associate Pastor of Adult Faith Formation

Lay Liturgists

8:30 AM Steve Sullivan
11:00 AM Lynne Trost

Music

8:30 AM Laudate Choir
11:00 AM Westminster Choir

John Semingson
Director of Music Ministries

Stephen Z. Cook
Organist

Communion Preparation

Rachel Gilmore

Flower Dedication

The flowers in the Sanctuary are given to the glory of God and in celebration of the marriage of Catherine Chowning Disspayne and Ethan Jacob Shoemaker on Saturday, April 18, 2026, and in loving memory of Catherine B. Sharp and William (Bill) Disspayne, grandparents of the bride.

Hearing Assistance

We offer two options to assist with hearing during services. 1.) Download the Sennheiser MobileConnect app. 2.) Personal FM receivers with an earpiece. Receivers and instructions for both options are located in the Narthex and on the Welsh Dresser in the Parlor. Please see an Usher if you need assistance.

Large Print Hymns

Looking for large-print hymns? They can be found in the Narthex at the Sanctuary entrance or in the Parlor on the Welsh dresser.

Recorded Worship Services

To watch a service at a later time, go to www.nashvillewpc.church and scroll down to the Worship Service Archive. Click on the service you would like to view.

Dial-a-Sermon

Dial 629.206.1073 after 10:15 AM each Sunday morning to listen to the sermon. The sermon will be available all week.

Childcare

Childcare is available on Sundays from 8:15 AM to 12:00 PM.

Nursery - Room 146

Toddlers - Room 152

2s and 3s - Room 151

Copyright Information

The music used in the service this morning is copyrighted under Christian Copyright Licensing International, Inc., No. 1121525.

Our Mission

Ordinary people testifying to the extraordinary light found in our Lord Jesus Christ.

"For it is the God who said, 'Let light shine out of darkness,' who has shone in our hearts to give the light of the knowledge of the glory of God in the face of Jesus Christ. But we have this treasure in clay jars, so that it may be made clear that this extraordinary power belongs to God and does not come from us."

(2 Corinthians 4:6-7)



TODAY @ WESTMINSTER



**LIVING
OUT THE
WORD**

LOVE
RECONCILE
SHINE
TRANSFORM

Now on that same day two of Jesus' disciples were going to a village called Emmaus, about seven miles from Jerusalem, and talking with each other about all these things that had happened. Luke 24:13

Has there ever been a time when your life was going in the wrong direction?

Why do you think Jesus disappears at the moment of recognition?

How has Jesus changed your trajectories in life?

Welcome

Westminster Presbyterian Church welcomes you to share our common journey to become more faithful disciples of Christ. If you are interested in joining us in this journey, you are invited to contact Stephanie Boaz, sboaz@nashvillewpc.org.

Welcome Rev. Sarah Bird Kneff

Please join us in the Parlor after the 8:30 AM and the 11:00 AM service for a welcome reception for our new Adult Faith Formation pastor. Enjoy sweet treats and creamy coffees from the Café and introduce yourself to the newest member of the Westminster ministry team.

Are you up-to-date on all the WPC news?

We send emails out to the congregation and community three plus times a week. On Monday, we send an email about our mission work. On Wednesdays, we send info about all the events we have going on throughout the month. On Fridays, the Sunday info is included in the email. We also have emails from our Children's, Youth and Young Families ministries. Please scan the QR code to sign up for the emails you would like to receive.





TODAY @ WESTMINSTER

Adult Education Classes start at 9:45 AM



Covenant Class • Fellowship Hall

Senses of Scripture: Medieval Biblical Interpretation Ministry series.

What, if anything, does Medieval Biblical Interpretation have to offer us in the 21st century? Come join Covenant class this April to find out! We'll look at how the "senses of Scripture"—a multifaceted approach to interpreting the Bible—offers a richer encounter with Scripture than sheer literalism or empty historicism. Along with an overview and exploration of Medieval Biblical Interpretation, we'll have a chance to test out these methods in class as well as think through the larger purposes and aims of exegesis.



Murdoch MacLeod • Library

We will discuss this week's gospel lesson.

For more info, please contact Paul DeWitt, pdewitt@comcast.net.



Journeys • Overlook Room

Fellowship Sunday

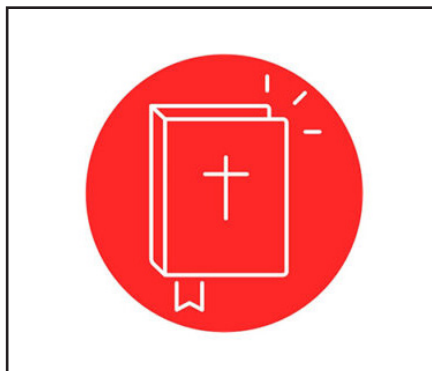

Women's Bible Study 7:00-8:30 PM

We are studying Rachel Held Evans' book *Inspired*. (Reading not required.)

Email Dana Hildebrand, dana.m.hildebrand@gmail.com, to get connected! We'd love to have you.



KOINONIA YOUTH MINISTRY

YOUTH TEAM

Adam DeVries
Parish Associate for Youth
adevries@nashvillewpc.org

Hannah Norris
Youth & Missions Program
Coordinator
hnorris@nashvillewpc.org

Jessie King
Youth & Pastoral Care Fellow
jking@nashvillewpc.org

Julius Hooper
MLC Youth Ministry Resident
WPCkoinoniastaff@gmail.com

Nathan Scott
Youth Ministry Intern
WPCkoinoniastaff@gmail.com



9:45 AM •
Sunday School •

Join us in the Café
for Sunday School.



6:00 PM •
Youth Group •
Koinonia Youth Café

GROG!

FIND THE FLASHLIGHT -- BRING THE LIGHT

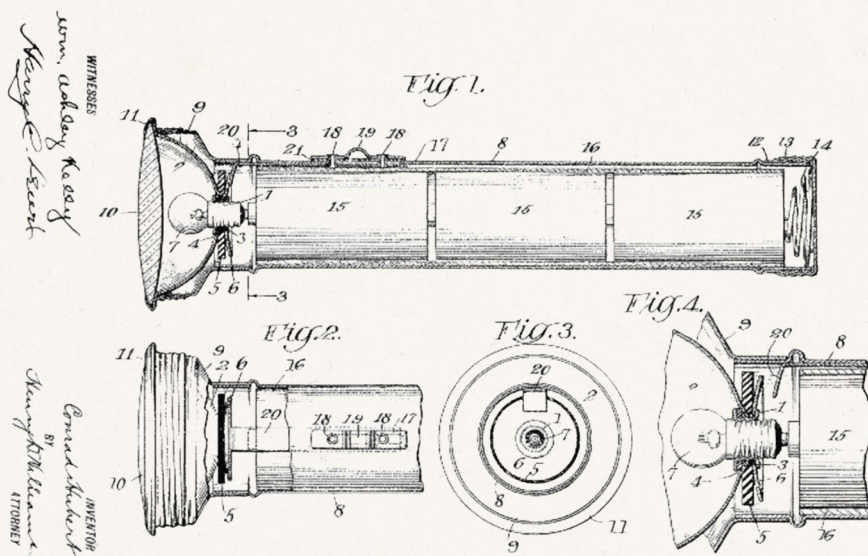

GROG IS COMING THIS APRIL 19TH



CHILDREN'S MINISTRY

8:30 & 11:00 AM • Worship Services

Children and Worship

Childcare is available for children who are infants through kindergarten during both services. While childcare is available, children are always welcome in worship. There are quiet toys and worship bags for children. They may be found in baskets in the Parlor and in the back of the Sanctuary. The bags have plain paper, crayons, a pencil and a children's bulletin.

9:45 AM • Sunday School

2s are in room 149

3s are in room 161

4s are in room 163

Godly Play/Kindergarten in 183

4th & 5th Grade in room 292

1st - 3rd Chapel first and then will be picked up in rooms.



Living Out *the* Word

In the story today after Jesus has died, two of his disciples are walking on the road to Emmaus. Another man joins them. They are sharing their story and do not know that it is Jesus walking with them.

Have you ever been totally surprised? How does it feel when something unexpected happens? Draw a picture of your favorite part of the story.

The Road to Emmaus

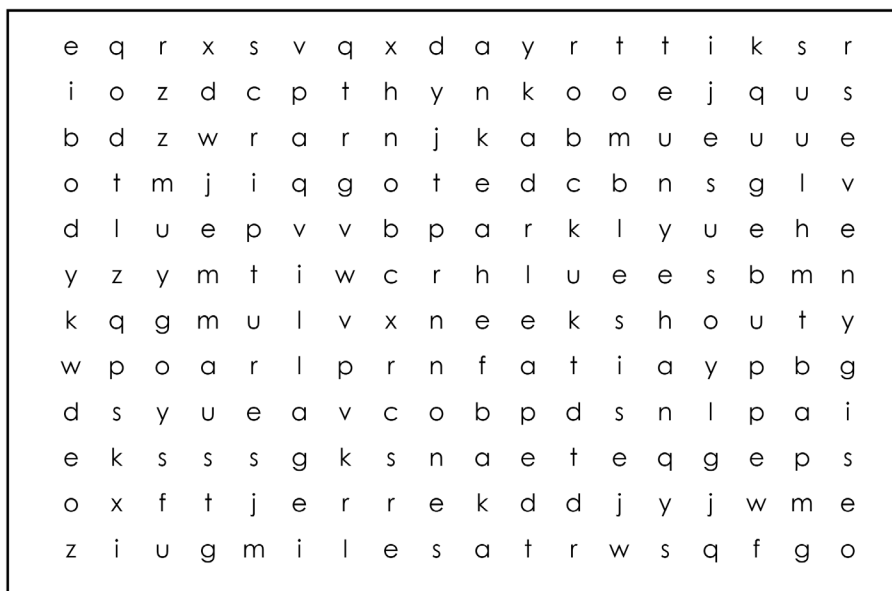

Word Search

See if you can find these words in the puzzle on the left.

body

Cleopas

Emmaus

Jesus

prophets

scriptures

talking

village

bread

day

Jerusalem

miles

road

seven

tomb



MUSIC MINISTRY



Sunday Rehearsals

Children, Youth & Intergenerational Choirs

4:00 PM Rehearsals
no rehearsals

5:00 PM Rehearsals
Laudate Choir

Music Camp 2026

Enroll your kids for Music Camp 2026, June 8-14!

Music Camp is a fun-filled week of singing, games, arts & crafts, costumes, and performing a biblical musical for the congregation on Sunday with opportunities for acting roles with lines and solos. All children, rising grades 1st-7th, are welcome, even if they are not currently involved in Children's Choir.



May 5 | 7:00 PM | Westminster Presbyterian Church



ANNOUNCEMENTS



Rescue 101 Back in Nashville

Rescue 101 SAR is a veteran-led organization dedicated to serving communities and individuals in Ohio and across the United States with search and rescue operations; emergency response; disaster preparation, response, and relief; and community education. We achieve this mission by mobilizing active and retired first responders, veterans, volunteers, and youth explorer volunteers to provide prompt, professional, and effective services to those in need at no cost. Their goal is to be a trusted partner for communities and individuals during times of crisis and to help build resilience through education and preparedness.

They are staying at WPC through April 29. Scan the QR code to learn more about this group.



April 28
Westminster Book Group
9:30 AM • Fellowship
10:00 AM • Presentation
Goodpasture Hall

Jonathan Rauch, author of *Cross Purposes*, asserts that the religion of mainline Christianity (the Presbyterian Church in the US and others) has become 'too thin to provide meaning and morals to the culture and thus to reliably support a democratic society'. We will discuss Rauch's assertion and his suggestions for addressing the apparent dysfunction in our society and its current government. Rauch, a life-long atheist, says: 'Don't be afraid. Imitate Jesus.'

Led by John Bailey.

April 26 **New Baby Families** **Gathering**

9:45 AM • Room 10

Join us and meet others whom you'll get to know as your children grow. If you have a new baby this year, we hope you'll join.

April 26 **Men's Bible Study** **7:00 PM** **Goodpasture Hall**

Contact Blake Brookshire, b.brookshire@vumc.org, for more info.

May 11 **Women's Covenant** **Group** **11:30 AM • BYO Lunch** **12:00 PM • Presentation** **Goodpasture Hall**

Save the date.



JOY IN LEARNING/CAFÉ



Join us for fun, food and fellowship in the Westminster Café or in a Joy in Learning Class. Please scan the QR code, where appropriate, for more info and to register.

OnGoing Events

Wednesdays

• **Watercolor Painting** | 10:00 AM - Noon | Westminster Café
Learn from each other. Come and go activity.



Thursdays

• **Fill My Cup** | Westminster Café
8:15 AM Meet and Greet | 8:30 AM Coffee/tea and percolating conversation
Come when you can. No sign ups necessary. Join other women in the Café to fill your spiritual cup. We will revisit the previous Sunday's scriptures.

Spring Specials in the Café

- Lemon-Ginger-Honey yummy hot or refreshing cold drink!
- Vietnamese/Mexican Coffee (cold brew with creamy sweet milk)
- Original or Dirty Chai Latte
- Cold Brew



Thursdays • April 16, 23, 30

Pottery Hand-Building

9:30 AM - Noon

\$40

For all Levels (Beginning and Experienced). A fun time for hand-building items to keep, give away, or donate to the church!



Tuesdays • April 28 & May 5, 12, 19

Beginning Pottery Session

9:15 - 11:45 AM

\$40.00 for 4 days (includes all supplies)

Leaders: Christine Nguyen and Janice Mann

Limit: 8 participants



GET ON THE LIST! Quilting Class

We are so excited to offer a quilting and weaving class in the near future. Right now we are asking folks to let us know what interests them and the days/times





MISSION OPPORTUNITIES



FaithWorks - Sign Up Now

April 25
8:00 AM -12:00 PM
12:00 PM • Lunch

Please join us for our annual day of service, where we go out as a whole church into the community to serve. All ages and stages are welcome. This year, we will add a Rise Against Hunger event (pack 10,000 meals) along with Habitat, WHC and PTM.



Make Tye-Dye Towels

This year, we have added a new agency to our FaithWorks line-up.

Shower The People provides showers and laundry for people experiencing homelessness. We will be making tye-dyed towels for this shower service during FaithWorks. Scan QR to register.



RISE Against Hunger

This year, we will have a RISE Against Hunger event and pack 10,000 meals for those in need during FaithWorks.

This is an activity for all ages.

Please register with the RISE Against Hunger organization AND with WPC.



MINISTRY TEAM



Donovan Drake
Pastor
ddrake@nashvillewpc.org



Will Wellman
Director of Theology and
Community Initiatives
wwellman@nashvillewpc.org



Sophie Maness
Exec Director of Children's
& Community Life Ministries
smaness@nashvillewpc.org



Stephanie Boaz
Associate Pastor for
Congregational Care
sboaz@nashvillewpc.org



Ashley Higgins
Associate Pastor
for Young Families
ahiggins@nashvillewpc.org



John Semingson
Director of Music Ministries
johns@nashvillewpc.org



Guy D. Griffith
Associate Pastor for
Pastoral Care and Teaching
ggriffith@nashvillewpc.org



Adam DeVries
Parish Associate for Youth
adevries@nashvillewpc.org



Stephen Z. Cook
Organist



Sarah Bird Kneff
Associate Pastor for
Adult Faith Formation
skneff@nashvillewpc.org



Hannah Norris
Youth & Missions Program
Coordinator
hnorris@nashvillewpc.org



3900 West End Avenue
Nashville, TN 37205-1899
615.292.5526
www.nashvillewpc.church