



Second Sunday of Easter  
Holy Baptism  
April 12, 2026

*Worship on the  
Lord's Day*

Worship begins as the people gather - greeting one another, praying in silence, or offering music to the glory of God. The act of assembling in Jesus' name bears witness to the Church's identity and mission as Christ's body in the world.

*About the Prelude*

The Prelude is a musical offering to help move the hearts and minds of the gathering community from the daily struggles of life to the worship of God.

*About Hymn 235*

These stanzas from a 19th-century translation of a 15th-century Latin text make up the Easter Sunday portion of a longer hymn. They are sung to a 15th-century French tune that probably originated outside the church but was adapted for religious texts.

## GATHERING

### CONCERNS OF THE CHURCH

#### \*CALL TO WORSHIP

Let us worship God!

*(Those who are able may stand.)*

Blessed be the God and Father  
of our Lord Jesus Christ.  
By his mercy God has given us a new birth  
into a living hope  
through the resurrection of Jesus Christ.  
**We rejoice, for we are children of God.**

We proclaim our faith:  
no power can overcome Christ's love,  
and as his body, we have received salvation.  
**In love and joy, we praise the Lord!**

#### PRELUDE

François Dandrieu  
Variations on "O Filii et Filiae"

#### \*PRAYER OF THE DAY

The Lord be with you. **And also with you.**

**Holy God, we sing your praises.  
You have brought us new life and freed us for love.  
Shake us free of anything that inhibits us  
from living fully as your new creation.  
Help us to live into your resurrection  
in relationships mended, wounds healed,  
communities restored, and wrongs made right,  
that we might reach for your hand  
and to witness together,  
"My Lord and my God!" Amen.**

*(The Cross and Bible lead the procession, symbolic of the centrality  
in worship of Jesus Christ - the Living Word,  
and the Bible - the written Word.)*

#### \*PROCESSIONAL HYMN 235

O FILII ET FILIAE

O Sons and Daughters, Let Us Sing

# 235 O Sons and Daughters, Let Us Sing

Al - le - lu - ia! Al - le - lu - ia! Al - le - lu - ia! Al -

le - lu - ia! 1 O sons and daugh - ters, let us sing with  
2 That Eas - ter morn, at break of day, the  
3 An an - gel clad in white they see, who  
4 That night the a - pos - tles met in fear; a -  
5 On this most ho - ly day of days, to

heaven - ly hosts to Christ our King; to - day the grave has  
faith - ful wom - en went their way to seek the tomb where  
sits, and speaks un - to the three, "Your Lord will go to  
mong them came their Lord most dear, and said, "My peace be  
God your hearts and voic - es raise, in laud and ju - bi -

lost its sting!  
Je - sus lay.  
Gal - i - lee." Al - le - lu - ia! Al - le - lu - ia!  
with you here."  
lee and praise.

These stanzas from a 19th-century translation of a 15th-century Latin text make up the Easter Sunday portion of a longer hymn. They are sung to a 15th-century French tune that probably originated outside the church but was adapted for religious texts.

## CALL TO CONFESSION

The Lord says: Come.  
Let anyone who wishes take the water of life as a gift.

Trusting in God's grace, let us confess our sin.

## PRAYER OF CONFESSION

**Almighty God,  
in raising Jesus from the grave,  
you shattered the power of sin and death.  
We confess that we remain captive to doubt and fear,  
bound by the ways that lead to death.  
We overlook the poor and the hungry,  
and pass by those who mourn;  
we are deaf to the cries of the oppressed,  
and indifferent to calls for peace;  
we despise the weak,  
and abuse the earth you made.**

**Forgive us, God of mercy.  
Help us to trust your power  
to change our lives and make us new,  
that we may know the joy of life abundant  
given in Jesus Christ, the risen Lord.**

*(Silent confession)*

## Kyrie

James MacMillan

(Organ introduction) **4** **1st-Choir/2nd-Congregation**

Lord, have mer-cy, Lord, have  
mer-cy. Christ, have mer-cy, Christ, have  
mer-cy. Lord, have mer-cy, Lord, have mer-cy.

*Call to and Prayer  
of Confession*

A call to confession expresses God's initiative in calling for repentance and promising forgiveness in Christ. As members of Christ's body, we confess the reality of sin, captivity, and brokenness in personal and common life and ask for God's saving grace.

*About the Kyrie*

The Kyrie (Greek "kyrios" [Lord]) is a corporate musical prayer for grace.

*Assurance of Pardon*

A declaration of forgiveness proclaims the good news of God's mercy and offers the assurance of pardon in Jesus' name. The liturgist pours water into the font, which reminds us of the grace and cleansing of our Baptism, and the baptismal call to new life in Christ.

*Act of Praise*

The Act of Praise brings together the choir and congregation to sing God's praise in response to the Assurance of Pardon

*Prayer for Illumination*

A Prayer for Illumination calls on the Holy Spirit to empower the reading, understanding, proclaiming, and living of God's word. This sense of utter reliance on the illumination of the Spirit is an important and distinctive mark of the Reformed tradition.

**ASSURANCE OF PARDON**

Believe the Good News: **In Jesus Christ we are forgiven!**

**\*The Peace**

Since God in Christ has forgiven us,  
let us also forgive one another.  
The peace of Christ be with you. **And also with you.**

*(Please exchange the peace with the words,  
"The peace of Christ be with you.")*

**\*ACT OF PRAISE**

John Weaver

Glory to God in the Highest

**(Please refer to the inside back cover of your hymnal  
for music for this hymn.)**

Glory to God in the highest, and peace to God's people on earth.

**Glory to God in the highest, and peace  
to God's people on earth.**

**Lord God, heavenly King, almighty God and Father,  
we worship You, we give You thanks,  
we praise You for Your glory.**

**Lord Jesus Christ, only Son of the Father,  
Lord God, Lamb of God,**

**You take away the sin of the world: have mercy on us;  
You are seated at the right hand of the Father:  
receive our prayer.**

**For You alone are the Holy One, You alone are the Lord,  
You alone are the Most High, Jesus Christ,  
with the Holy Spirit, in the glory of God the Father.**

**THE WORD**

**PRAYER FOR ILLUMINATION**

**SCRIPTURE**

**Psalm 16, Hymn 810**

ST. FLAVIAN

All Sing

Hear the Word of God! **Our ears are open.**

**John 20:19-31**

*(New Testament, page 115 in your pew Bible)*

## 810 When in the Night I Meditate

(Psalm 16)

1 When in the night I med - i - tate on  
 2 For - ev - er in my thought, the Lord be -  
 3 My in - most be - ing thrills with joy and  
 4 I know that I shall not be left for -  
 5 The path of life you show to me; of

mer - cies mul - ti - plied, my grate - ful heart in -  
 fore my face shall stand; se - cure, un - moved I  
 glad - ness fills my breast; be - cause on God my  
 got - ten in the grave, and from cor - rup - tion,  
 joy a bound - less store is ev - er found at

spires my tongue to bless the Lord, my guide.  
 shall re - main, with God at my right hand.  
 trust is stayed, my flesh in hope shall rest.  
 you, O Lord, your ho - ly one will save.  
 your right hand, and plea - sures ev - er - more.

Corresponding to Psalm 16:7–11, these five stanzas celebrating God's guidance and protection formed the second half of a paraphrase of the full psalm in their original publication. These words are set to a 16th-century psalm tune that has been effective with many texts.

The Word of the Lord. **Thanks be to God!**

**SERMON**

Margaret Grun Kibben  
"Blessed Are the Doubters"

*(A moment for meditation)*

**\*HYMN 485**

We Know That Christ is Raised

ENGELBERG

## **SACRAMENT OF BAPTISM**

### **Presentation**

Hear the words of our Lord Jesus Christ...

**Obeying the word of our Lord Jesus,  
and confident of his promises,  
we baptize those whom God has called.**

**In baptism God claims us and seals us  
to show that we belong to God.  
God frees us from sin and death,  
uniting us with Jesus Christ  
in his death and resurrection.  
By water and the Holy Spirit,  
we are made members of the Church,  
the body of Christ,  
and joined to Christ's ministry  
of love, peace, and justice.  
Let us remember with joy our own baptism,  
as we celebrate this sacrament.**

**Questions to the Parents, Congregation, and Children of the Church**

### **\*Profession of Faith**

Through baptism we enter the covenant...  
With the whole Church, let us confess our faith.

Do you believe in God, the Father almighty?

**I believe in God, the Father almighty,  
creator of heaven and earth.**



The sacrament  
of baptism will be  
administered today  
at the 8:30 AM  
worship service to:

**Grayson Ann  
Ward**

daughter of Andy  
and Beth Ward

**Adeline Elizabeth  
Ward**

daughter of Andy  
and Beth Ward



The sacrament  
of baptism will be  
administered today  
at the 11:00 AM  
worship service to:

**Elowyn Anne  
Norris**

daughter of Hannah  
and Rebecca Norris

# We Know That Christ Is Raised 485

Capo 3: (D) (Asus) (A) (A/G) (D/F#)  
 F Csus C C/B<sup>b</sup> F/A

1 We know that Christ is raised and dies no more.  
 2 We share by wa - ter in his sav - ing death.  
 3 The Fa - ther's splen - dor clothes the Son with life.  
 4 A new cre - a - tion comes to life and grows

(D) (A) (D) (E7) (A)  
 F C F G7 C

Em - braced by death he broke its fear - ful hold,  
 Re - born we share with him an Eas - ter life  
 The Spir - it's pow - er shakes the church of God.  
 as Christ's new bod - y takes on flesh and blood.

(Am) (D) (G) (Em) (Bm)  
 Cm F B<sup>b</sup> Gm Dm

and our de - spair he turned to blaz - ing joy.  
 as liv - ing mem - bers of a liv - ing Christ.  
 Bap - tized we live with God the Three in One.  
 The u - ni - verse, re - stored and whole, will sing:

1-3 4  
 (Em) (D) (Asus) (A) (Em) (D)  
 Gm F Csus C Gm F

Al - le - lu - ia! Al - le - lu - ia!

*Guitar chords do not correspond with keyboard harmony.*

Beginning with an allusion to Romans 6:9, this exuberant baptismal hymn unfolds the implications of our incorporation into Christ's new life, making us "a new creation" (2 Corinthians 5:17). The text was written to fit this expansive tune by a distinguished British composer.

TEXT: John Brownlow Geyer, 1967, alt.  
 MUSIC: Charles Villiers Stanford, 1904  
 Text © 1972 John Brownlow Geyer

ENGELBERG  
 10.10.10.4  
 (this tune in a higher key, 641)

## *The Baptismal Rite*

The Apostles' Creed: The oldest surviving baptismal liturgy, dating from around the year 200 C.E., describes the candidate for baptism standing in water and affirming the faith by responding to three questions. Each question corresponds to one person of the Trinity. The Paschal Candle is symbolic of Christ's death and resurrection. The Lamb of God, who takes away the sin of the world, is our Paschal sacrifice. The Paschal Candle also symbolizes the light of the risen Christ, shining in the world. The use of this symbol dates from the early days of the Church. New Christians were given a lighted candle, symbolic of their having died and been raised to new life in Christ through baptism.

Do you believe in Jesus Christ?

**I believe in Jesus Christ, God's only Son, our Lord, who was conceived by the Holy Spirit, born of the Virgin Mary, suffered under Pontius Pilate, was crucified, died, and was buried; he descended to the dead. On the third day he rose again; he ascended into heaven; he is seated at the right hand of the Father; and he will come to judge the living and the dead.**

Do you believe in the Holy Spirit?

**I believe in the Holy Spirit, the holy catholic Church, the communion of saints, the forgiveness of sins, the resurrection of the body, and the life everlasting. Amen.**

### **Thanksgiving over the Water**

The Lord be with you. **And also with you.**

Let us give thanks to the Lord our God.  
**It is right to give our thanks and praise.**

Eternal and gracious God...lives and reigns forever. Amen.

### **The Baptism**

#### **Welcome**

Let us welcome these newly baptized into the household of God.

**With joy and thanksgiving, we welcome you into Christ's Church to share with us in his ministry, for we are all one in Christ.**

#### **Baptismal Anthem**

8:30 AM

Barrie Cabena

Loving Shepherd of Thy Sheep

Loving shepherd of Thy sheep,  
Keep Thy Lambs in safety keep,  
Nothing can Thy power withstand,  
None can pluck them from Thy Hand.  
Alleluia.

Loving Shepherd, ever near,  
Teach Thy Lambs Thy voice to hear:  
Suffer not their steps to stray  
From the straight and narrow way.  
Alleluia.

Where thou leadest I would go,  
Walking in Thy steps below,  
Till before my Father's throne  
I shall know as I am known.  
Alleluia.

11:00 AM

Fred Gramann

With This Water

With this water begins the journey;  
With this water forever claimed.  
With this water the Lord now leads you.  
With this water forever changed.

With these vows your loved ones name you.  
With these vows your family grows.  
With these vows this congregation  
Now surrounds you, God's love to show.

With this water we celebrate now.  
With this water let us recall  
The baptism of our Savior,  
Who laid down His life for all.

## THANKSGIVING

### OFFERING

Anthem

8:30 AM

David M. Cherwien

Prayer for Peace

O God of love, O King of peace,  
Make wars throughout the world to cease;  
The wrath of nations now restrain.  
Give peace, O God, give peace again.

Remember, Lord, thy works of old,  
The wonders that thy people told;  
Remember not our sin's dark stain.

Whom shall we trust but thee, O Lord?  
Where rest but on thy faithful word?  
None ever called on thee in vain.

### *Offering*

The collection of tithes and offerings takes place as a response to the Word. These actions are signs of our gratitude for the grace of God proclaimed in the gospel.

To give, please scan the QR code below:



## Easter Carol

After darkness, Light; After Winter, Spring:  
After dying, Life: Alleluia!

Take his body down; Lay it in the tomb;  
Love has overcome: Alleluia!

Turn away in grief; Turn away in faith;  
Celebrate his death: Alleluia!

Come whatever may; God will have his way;  
Welcome Easter Day! Alleluia!

*Doxology*

A short hymn of  
praise to the triune  
God (God, Jesus  
Christ, Holy Spirit).

**\*DOXOLOGY**

LASST UNS ERFREUEN

**Praise God, from whom all blessings flow;  
Praise God, all creatures here below: Alleluia! Alleluia!  
Praise God, the source of all our gifts!  
Praise Jesus Christ, whose power uplifts!  
Praise the Spirit, Holy Spirit! Alleluia! Alleluia! Alleluia!**

**\*PRAYER OF THANKSGIVING**

The Lord be with you. **And also with you.**  
Let us give thanks to the Lord our God.  
**It is right to give our thanks and praise.**

**Eternal God,  
We praise you that your glory has dawned on us,  
and brought us into this Eastertide.  
We rejoice that the grave could not hold your Son,  
and that he has conquered death, risen to rule over all  
powers of this earth.  
We praise you that he summons us into new life,  
to follow him with joy and gladness.  
By your Spirit,  
lift us from doubt and despair,  
and set our feet in Christ's holy way,  
that our lives may be signs of his life,  
and all we have may show forth his love.  
Praise, glory, and thanksgiving to you,  
our God, forever and ever. Amen.**

**\*THE LORD'S PRAYER**

**Our Father, who art in heaven,  
hallowed be thy name,  
thy kingdom come,  
thy will be done,  
on earth as it is in heaven.  
Give us this day our daily bread;  
and forgive us our debts,  
as we forgive our debtors;  
and lead us not into temptation,  
but deliver us from evil.  
For thine is the kingdom, and the power,  
and the glory, forever. Amen.**

**SENDING**

**\*HYMN 240**

Alleluia, Alleluia! Give Thanks

**ALLELUIA**

**\*BENEDICTION**

**POSTLUDE**

Toccata on "O Filii et Filiae"

Lynwood Farnham

---

*\*(Those who are able may stand.)*

*About Hymn 240*

This text and tune were created together in the context of an ecumenical, charismatic, missionary Christian community in Ann Arbor, Michigan. Their energy and emphasis center in the opening and closing refrain's "Alleluia"—the essential Easter word of proclamation.

*About the Postlude*

The Postlude is considered the final Alleluia of worship.

# 240 Alleluia, Alleluia! Give Thanks

*Descant*

Al - le - lu - ia, al - le - lu - ia,

*Refrain* E C#m F#m B  
Al - le - lu - ia, al - le - lu - ia! Give thanks to the ris - en Lord. Al - le -

*Fine*  
al - le - lu - ia! Praise to his name.

E C#m F#m B E  
lu - ia, al - le - lu - ia! Give praise to his name.

E C#m F#m B  
1 Je - sus is Lord of all the earth.  
2 Spread the good news o'er all the earth:  
3 We have been cru - ci - fied with Christ.  
4 Come let us praise the liv - ing God,

E C#m F#m B *to Refrain*  
He is the King of cre - a - tion.  
Je - sus has died and has ris - en.  
Now we shall live for - ev - er.  
joy - ful - ly sing to our Sav - ior.

This text and tune were created together in the context of an ecumenical, charismatic, missionary Christian community in Ann Arbor, Michigan. Their energy and emphasis center in the opening and closing refrain's "Alleluia"—the essential Easter word of proclamation.

## Today @ Westminster

### Worship Leaders

#### Preaching

Rev. Dr. Margaret Grun Kibben

#### Liturgist

Rev. Dr. Guy D. Griffith

Associate Pastor for Pastoral Care and Teaching

8:30 AM Sophie Maness  
11:00 AM Rev. Stephanie Boaz

#### Lay Liturgists

8:30 AM Jane Kirchener  
11:00 AM Bob Hines

#### Presenting Elder

8:30 AM Devin Childers  
11:00 AM Bob Hines

#### Music

8:30 AM Laudate Choir  
11:00 AM Westminster Choir

John Semingson  
Director of Music Ministries

Stephen Z. Cook  
Organist

### Flower Dedication

The flowers in the Sanctuary are given to the glory of God and in loving memory of Bob Christie by Bill and Kelly Christie.

With gratitude to God for his faithful ministry, and his service as interim pastor of Westminster Presbyterian 2009-2010, the Parlor flowers are given in loving memory of Rev. Dr. O. Benjamin Sparks III by Guy and Amy Griffith.

### Red Rose

The red rose in the Chancel gives glory and thanksgiving to God for the birth of a son, *Matthew Robert James II*, on March 26, 2026, to Julie Ann and Matt James. CeCe is a welcoming big sister.

#### Hearing Assistance

We offer two options to assist with hearing during services. 1.) Download the Sennheiser MobileConnect app. 2.) Personal FM receivers with an earpiece. Receivers and instructions for both options are located in the Narthex and on the Welsh Dresser in the Parlor. Please see an Usher if you need assistance.

#### Large Print Hymns

Looking for large-print hymns? They can be found in the Narthex at the Sanctuary entrance or in the Parlor on the Welsh dresser.

#### Recorded Worship Services

To watch a service at a later time, go to [www.nashvillewpc.church](http://www.nashvillewpc.church) and scroll down to the Worship Service Archive. Click on the service you would like to view.

#### Dial-a-Sermon

Dial 629.206.1073 after 10:15 AM each Sunday morning to listen to the sermon. The sermon will be available all week.

#### Childcare

Childcare is available on Sundays from 8:15 AM to 12:00 PM.

Nursery - Room 146

Toddlers - Room 152

2s and 3s - Room 151

#### Copyright Information

The music used in the service this morning is copyrighted under Christian Copyright Licensing International, Inc., No. 1121525.

#### Our Mission

Ordinary people testifying to the extraordinary light found in our Lord Jesus Christ.

"For it is the God who said, 'Let light shine out of darkness,' who has shone in our hearts to give the light of the knowledge of the glory of God in the face of Jesus Christ. But we have this treasure in clay jars, so that it may be made clear that this extraordinary power belongs to God and does not come from us."

(2 Corinthians 4:6-7)



# TODAY @ WESTMINSTER

## Welcome

Westminster Presbyterian Church welcomes you to share our common journey to become more faithful disciples of Christ. If you are interested in joining us in this journey, you are invited to contact Stephanie Boaz, [sboaz@nashvillewpc.org](mailto:sboaz@nashvillewpc.org).



We welcome to our pulpit this morning, the Rev. Dr. Margaret Grun Kibben (Rear Admiral - ret.) who is the 61st Chaplain of the United States House of Representatives, a position she began on January 3, 2021.

Prior to her current role, she also served as the 26th Chief of Chaplains of the United States Navy and was formerly the 18th Chaplain of the United States Marine Corps. An ordained Presbyterian minister, Margaret holds her Masters of Divinity and Doctor of Divinity degrees from Princeton Theological Seminary. She serves as a Trustee on the Outreach Foundation Board, which is holding its spring Board meeting at WPC April 13-14.

## Are you up-to-date on all the WPC news?

We send emails out to the congregation and community three plus times a week. On Monday, we send an email about our mission work. On Wednesdays, we send info about all the events we have going on throughout the month. On Fridays, the Sunday info is included in the email. We also have emails from our Children's, Youth and Young Families ministries.

Please scan the QR code to sign up for the emails you would like to receive.



### Baptisms

**Baptism Sunday is the second and fifth Sundays of each month except during Lent.**

**If you would like more information about baptisms at Westminster, please contact Sophie Maness, 615.292.5526, [smaness@nashvillewpc.org](mailto:smaness@nashvillewpc.org).**

**If you would like to schedule a baptism, please contact Hannah Boles, 615.292.5526, [hboles@nashvillewpc.org](mailto:hboles@nashvillewpc.org).**



# ANNOUNCEMENTS

## Financials

Each month, the Finance Committee provides a summary of the church operating income and expenses.

If any members wish to have more information about church finances, please contact:

Mike Koban, Finance Committee Chair  
mkoban@prodigy.net

Suzanne McLemore, Treasurer  
suzannegm58@gmail.com

Jo Ann McFarlin, Administrator  
jmcfarlin@nashvillewpc.org or  
615.292.5526 x231.

March 2026

Year to Date

Income: \$1,371,646

Expense: \$1,037,664

Net Income (loss):

\$ 333,982

## Update Your Membership Contact Info

Contact Hannah Boles, Membership Secretary, hboles@nashvillewpc.org, to update your contact info or your photo. Hannah can also help you to access the online church member directory.

*Let's go to*  
**NaCoMe**

Two Days | **APRIL** | 18  
19

Come for One Day  
Come For Both Days

CAMP . FOOD . MUSIC . ADVENTURE

Scan QR Code to register.



# TODAY @ WESTMINSTER

Adult Education Classes start at 9:45 AM



## Covenant Class • Fellowship Hall

***Senses of Scripture: Medieval Biblical Interpretation Ministry series.***

What, if anything, does Medieval Biblical Interpretation have to offer us in the 21st century? Come join Covenant class this April to find out! We'll look at how the "senses of Scripture"—a multifaceted approach to interpreting the Bible—offers a richer encounter with Scripture than sheer literalism or empty historicism. Along with an overview and exploration of Medieval Biblical Interpretation, we'll have a chance to test out these methods in class as well as think through the larger purposes and aims of exegesis.

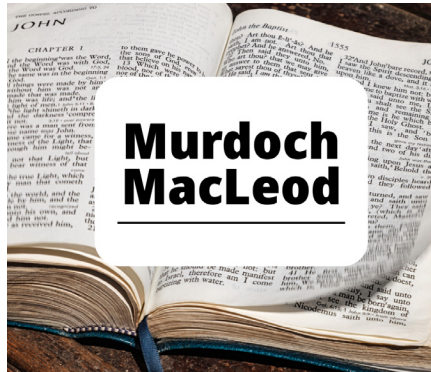

## Murdoch MacLeod • Library

We will discuss this week's gospel lesson.

For more info, please contact Paul DeWitt, pdewitt@comcast.net.



## Journeys • Overlook Room

Join us for Sunday School.

For more info, please contact Krissie Self, krissiebsself@gmail.com.



# TODAY @ WESTMINSTER



## Children, Youth & Intergenerational Choirs

4:00 PM Rehearsal: Tintinnabulation

5:00 PM Rehearsal: Laudate



*For men in their late 20s to early 50s*

## Men's Bible Study: Scripture for Today

7:00 PM • Goodpasture Hall

*Meets every other Sunday*

This group will have discussion centering on the week's lectionary text. Conversation will dig into scripture and its implications for us today. Leaders: Donovan, Guy and Will Wellman.

Contact: Blake Brookshire [b.brookshire@vumc.org](mailto:b.brookshire@vumc.org)



**May 5 | 7:00 PM | Westminster Presbyterian Church**



# KOINONIA YOUTH MINISTRY

## YOUTH TEAM

Adam DeVries  
Parish Associate for Youth  
adevries@nashvillewpc.org

Hannah Norris  
Youth & Missions Program  
Coordinator  
hnorris@nashvillewpc.org

Jessie King  
Youth & Pastoral Care Fellow  
jking@nashvillewpc.org

Julius Hooper  
MLC Youth Ministry Resident  
WPCkoinoniastaff@gmail.com

Nathan Scott  
Youth Ministry Intern  
WPCkoinoniastaff@gmail.com



**9:45 AM •**  
**Sunday School •**

Join us in the Café  
for Sunday School.



**6:00 PM •**  
**Youth Group •**  
**Koinonia Youth Café**

Join us for fun, food  
and fellowship.

FIND THE FLASHLIGHT -- BRING THE LIGHT

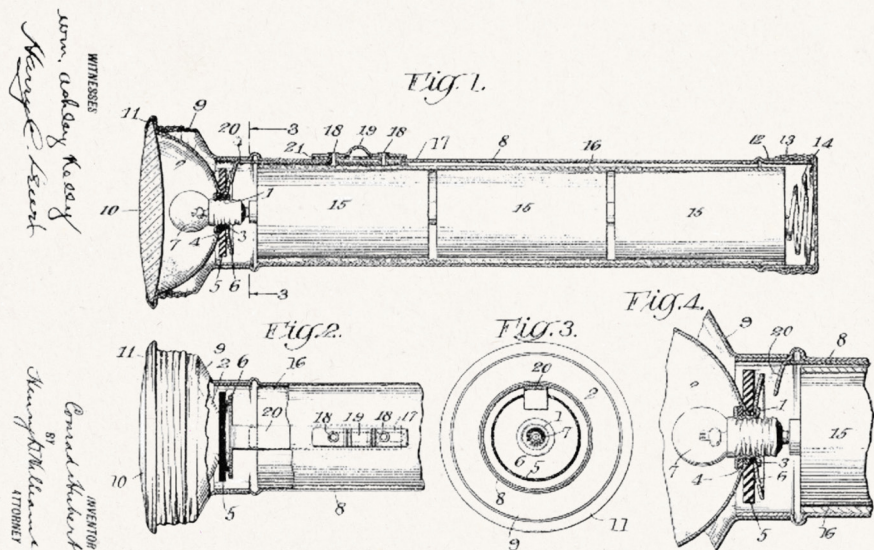

L.157,395.

C. ROBERT,  
PORTABLE ELECTRIC LIGHT.  
APPLICATION FILED DEC. 16, 1911.

Patented Oct. 19, 1915.

GROG IS COMING THIS APRIL 19TH



# CHILDREN'S MINISTRY

## 8:30 & 11:00 AM • Worship Services

### Children and Worship

Childcare is available for children who are infants through kindergarten during both services. While childcare is available, children are always welcome in worship. There are quiet toys and worship bags for children. They may be found in baskets in the Parlor and in the back of the Sanctuary. The bags have plain paper, crayons, a pencil and a children's bulletin.

## 9:45 AM • Sunday School

**2s are in room 149**

**3s are in room 161**

**4s are in room 163**

**Godly Play/Kindergarten in 183**

**4<sup>th</sup> & 5<sup>th</sup> Grade in room 292**

**1<sup>st</sup> - 3<sup>rd</sup> Chapel first and then will be picked up in rooms.**

## Peace Be With You

e	x	q	q	h	c	t	l	z	p	s	u	h	b	n	d	u	e
s	h	z	t	x	q	s	e	d	u	e	t	b	e	p	i	v	s
h	o	s	w	i	j	f	s	p	p	p	a	g	b	g	s	z	f
h	l	i	s	n	s	e	m	t	f	l	h	c	i	g	c	p	e
p	y	n	f	b	s	f	s	k	y	i	n	g	e	d	i	d	y
v	s	s	o	d	m	b	u	u	x	w	r	u	s	q	p	p	t
u	p	q	r	l	w	o	x	o	s	k	v	s	k	w	l	j	i
q	i	i	g	y	n	x	t	f	b	f	w	r	t	s	e	t	h
u	r	x	i	b	e	l	i	e	v	e	b	k	h	t	s	k	g
b	i	a	v	p	e	k	e	t	q	i	q	z	t	c	g	c	e
w	t	b	e	m	v	t	h	o	m	a	s	j	p	q	c	n	j
d	a	b	v	i	v	h	t	h	a	n	d	s	p	v	r	f	q

## Word Search

See if you can find these words in the puzzle on the left.

believe  
first  
hands  
Jesus  
sins

disciples  
forgive  
Holy Spirit  
peace  
Thomas



# ANNOUNCEMENTS

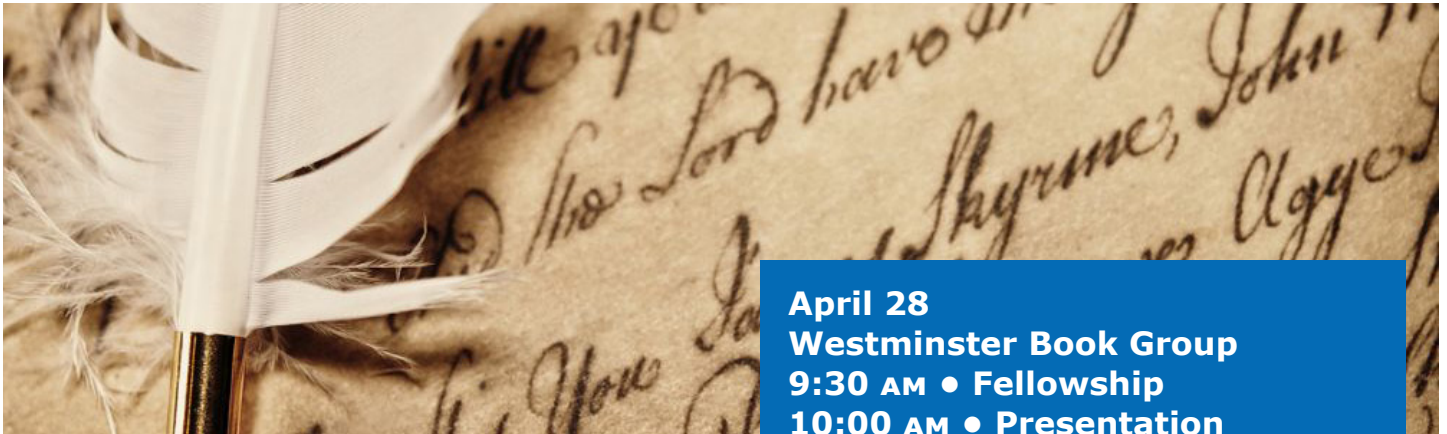

**April 13**

**Women's Covenant Group**

**11:30 AM • BYO Lunch**

**12:00 PM • Presentation**

Our speaker will be Emily Reynolds, former Secretary of the Senate and member of Westminster, who will speak to us on "Tales and Traditions of the U.S. Senate."

Everyone is welcome - men and women!

We look forward to seeing you there!

Lisa Atkinson, lbas1958@gmail.com

Frances Baird, fbbaird@yahoo.com

Suzanne Allen, sallen2009@gmail.com

**April 28**

**Westminster Book Group**

**9:30 AM • Fellowship**

**10:00 AM • Presentation**

**Goodpasture Hall**

**Jonathan Rauch, author of *Cross Purposes*, asserts that the religion of mainline Christianity (the Presbyterian Church in the US and others) has become 'too thin to provide meaning and morals to the culture and thus to reliably support a democratic society'. We will discuss Rauch's assertion and his suggestions for addressing the apparent dysfunction in our society and its current government. Rauch, a life-long atheist, says: 'Don't be afraid. Imitate Jesus.'**

**Led by John Bailey.**



# JOY IN LEARNING/CAFÉ



Join us for fun, food and fellowship in the Westminster Café or in a Joy in Learning Class. Please scan the QR code, where appropriate, for more info and to register.

## **OnGoing Events**

### **Wednesdays**

• **Watercolor Painting** | 10:00 AM - Noon | Westminster Café  
Learn from each other. Come and go activity.



### **Thursdays**

• **Fill My Cup** | Westminster Café  
8:15 AM Meet and Greet | 8:30 AM Coffee/tea and percolating conversation  
Come when you can. No sign ups necessary. Join other women in the Café to fill your spiritual cup. We will revisit the previous Sunday's scriptures.

---

## **Spring Specials in the Café**

- Lemon-Ginger-Honey yummy hot or refreshing cold drink!
- Vietnamese/Mexican Coffee (cold brew with creamy sweet milk)
- Original or Dirty Chai Latte
- Cold Brew



---

## **Thursdays • April 9, 16, 23, 30** **Pottery Hand-Building**

9:30 AM - Noon  
\$40

For all Levels (Beginning and Experienced). A fun time for hand-building items to keep, give away, or donate to the church!



---

## **Tuesdays • April 28 & May 5, 12, 19** **Beginning Pottery Session**

9:15 - 11:45 AM  
\$40.00 for 4 days (includes all supplies)  
Leaders: Christine Nguyen and Janice Mann  
Limit: 8 participants



---

## **GET ON THE LIST! Quilting Class**

We are so excited to offer a quilting and weaving class in the near future. Right now we are asking folks to let us know what interests them and the days/times





# MISSION OPPORTUNITIES



## FaithWorks - Sign Up Now

**April 25**  
**8:00 AM -12:00 PM**  
**12:00 PM • Lunch**

Please join us for our annual day of service, where we go out as a whole church into the community to serve. All ages and stages are welcome. This year, we will add a Rise Against Hunger event (pack 10,000 meals) along with Habitat, WHC and PTM.



## Make Tye-Dye Towels

This year, we have added a new agency to our FaithWorks line-up.

Shower The People provides showers and laundry for people experiencing homelessness. We will be making tye-dyed towels for this shower service during FaithWorks. Scan QR to register.



## RISE Against Hunger

This year, we will have a RISE Against Hunger event and pack 10,000 meals for those in need during FaithWorks.

This is an activity for all ages.

Please register with the RISE Against Hunger organization AND with WPC.



---

# MINISTRY TEAM



Donovan Drake  
Pastor  
ddrake@nashvillewpc.org



Will Wellman  
Director of Theology and  
Community Initiatives  
wwellman@nashvillewpc.org



Sophie Maness  
Ex Director of Children's &  
Community Life Ministries  
smaness@nashvillewpc.org



Stephanie Boaz  
Associate Pastor for  
Congregational Care  
sboaz@nashvillewpc.org



Ashley Higgins  
Associate Pastor  
for Young Families  
ahiggins@nashvillewpc.org



John Semingson  
Director of Music Ministries  
johns@nashvillewpc.org



Guy D. Griffith  
Associate Pastor for  
Pastoral Care and Teaching  
ggriffith@nashvillewpc.org



Adam DeVries  
Parish Associate for Youth  
adevries@nashvillewpc.org



Stephen Z. Cook  
Organist



Sarah Bird Kneff  
Associate Pastor for  
Adult Faith Formation  
skneff@nashvillewpc.org



Hannah Norris  
Youth & Missions Program  
Coordinator  
hnorris@nashvillewpc.org



3900 West End Avenue  
Nashville, TN 37205-1899  
615.292.5526  
www.nashvillewpc.church